

LF150 Wheel unit for rudder control



LF150 is a rudder control unit designed for electronic control. The full size standard wheel can be turned maximum 280°. The LF150 wheel unit for rudder control includes potentiometer and visible panel plate.

Note: Different wheels available as option.

Talk to us:
+47 33 03 18 50
sales@lilaas.no

More information
www.lilaas.no

LF150 Wheel unit for Rudder Control

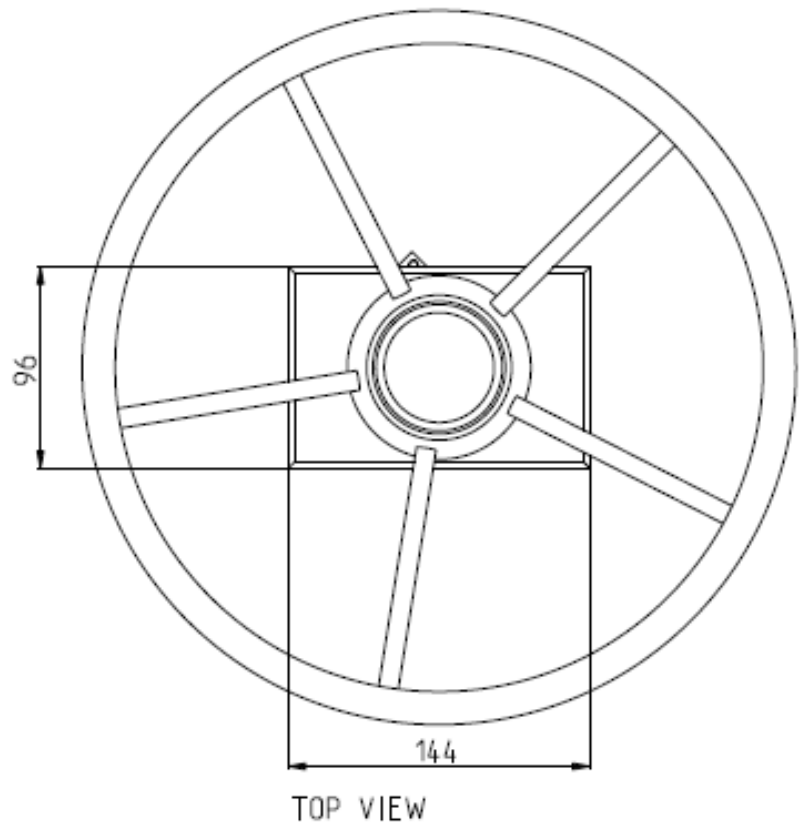
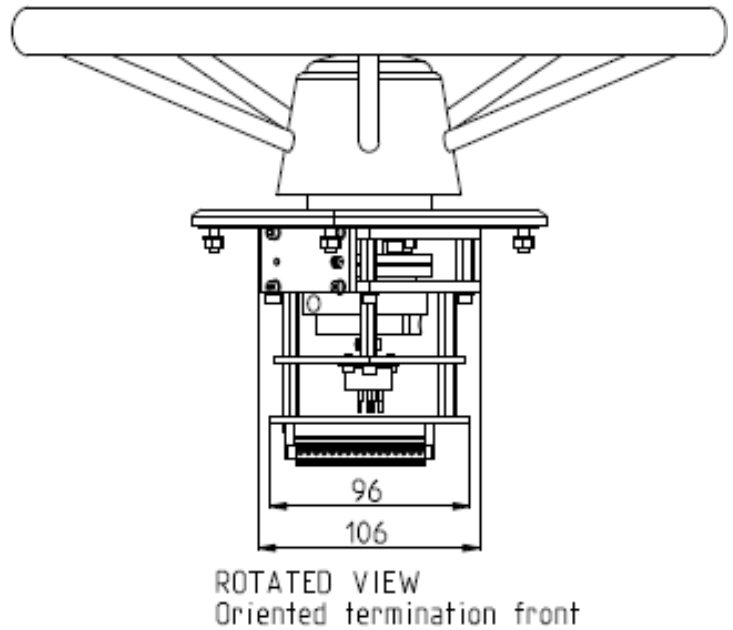
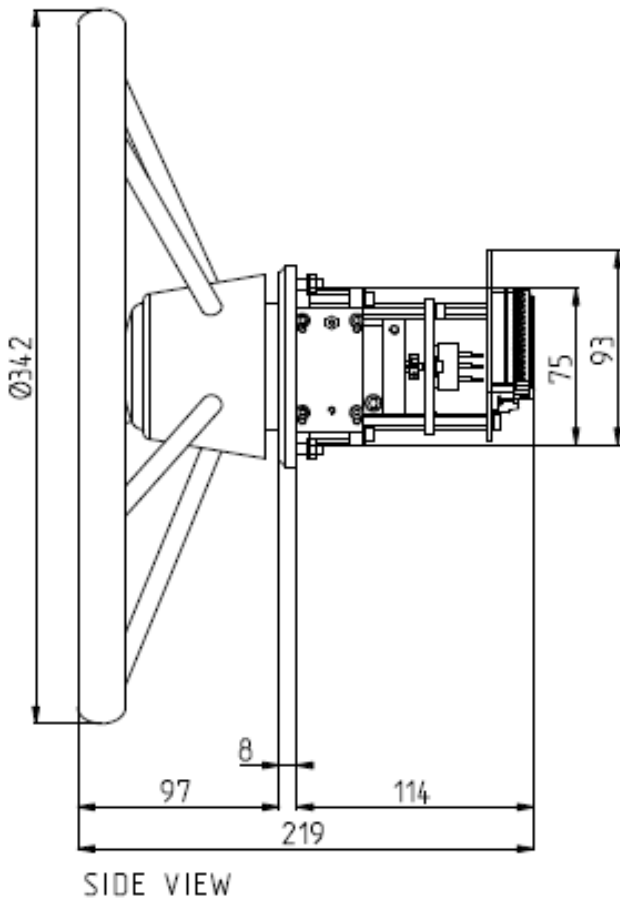

Technical description, standard

Panel plate:	Coated aluminium
Scale:	Self-adhesive
Standard potentiometers:	5K
Standard termination:	16 pins contact with plug
Enclosure:	IP56
Type approval:	EN/IEC 60945, ABS, BV, DNV, GL, KR, LR, NK, RINA, PRS, RS, CRS

Options

Spring-loaded return to neutral

Other options on request