

## LF90 Motorized control lever

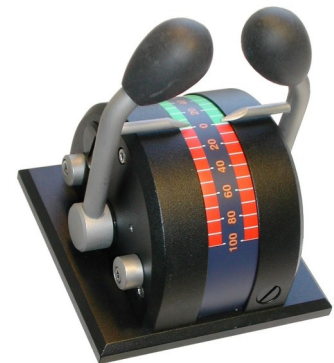

Single or double motorized operation of tunnel thrusters / propulsion machinery.

LF90 motorized are designed for single or double operation of tunnel thrusters and propulsion machinery, prepared to operate with Lilaas or customer el-shaft system. Small, robust and established as one of the most reliable maritime control levers on the market.

The standard lever may be modified according to customer's requirements, such as different scales, straight or curved shafts (standard Lilaas thruster control = curved shafts), different handles, potentiometers, detents and switch operation.

Note: Separate product sheets for Lilaas el-shaft and non motorized LF90.

Talk to us:  
+47 33 03 18 50  
sales@lilaas.no

More information  
www.lilaas.no

# Motorized control lever LF90

Outline sketch also valid for single lever (only one handle and one set of mechanical parts below panel plate)

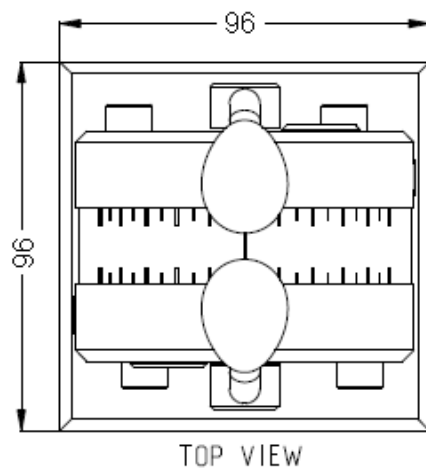
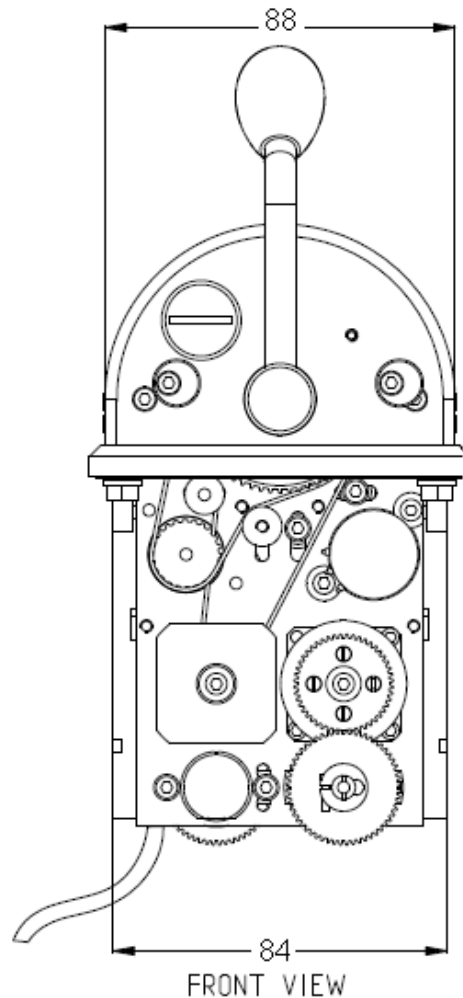
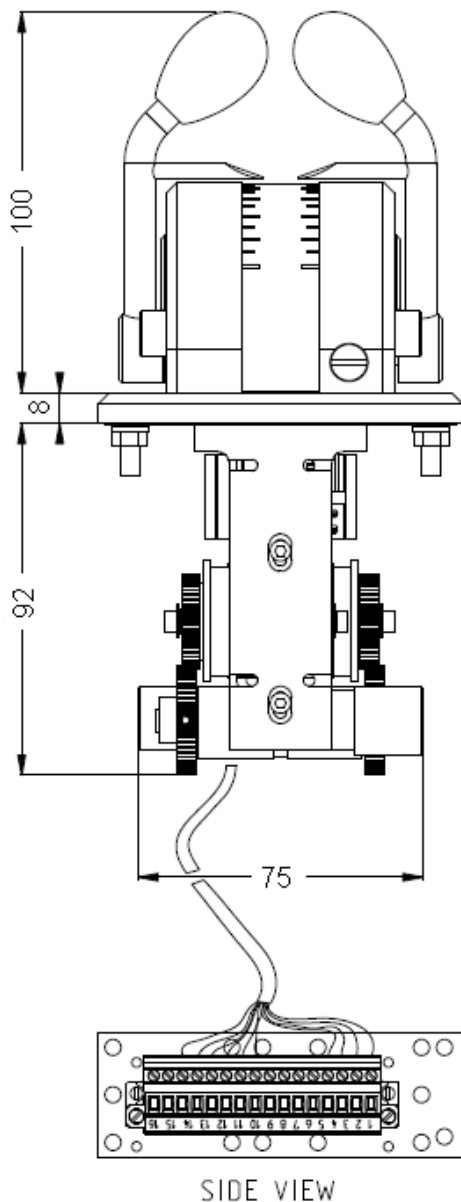

## Technical description, standard

Side covers:	Black coated aluminium
Shaft:	Flat finished stainless steel
Handle:	Flat finished POM
Scale:	Self adhesive on acrylic bow
Standard scale light:	24 volts
Standard potmeter:	5 K
Potmeter operation:	Tooth belt
Standard termination:	16 pins contact with plug
Panel plate:	96x96 mm (IP66)
Type approval:	EN/IEC 60945, ABS, BV, DNV, GL, KR, LR, NK, RINA, PRS, RS, CRS

## Options, single and double

- Spring-loaded return to neutral position
- Built-in switches
- Various handles and shafts
- Detents, limited deflection
- Handle interlock on/off on straight shafts
- Different panel plates
- A range of scale foils, thruster or propulsion versions, integrated scale light
- Other options on request